

# Vario-Sonnar® T\* 3.5-5.6/28-80

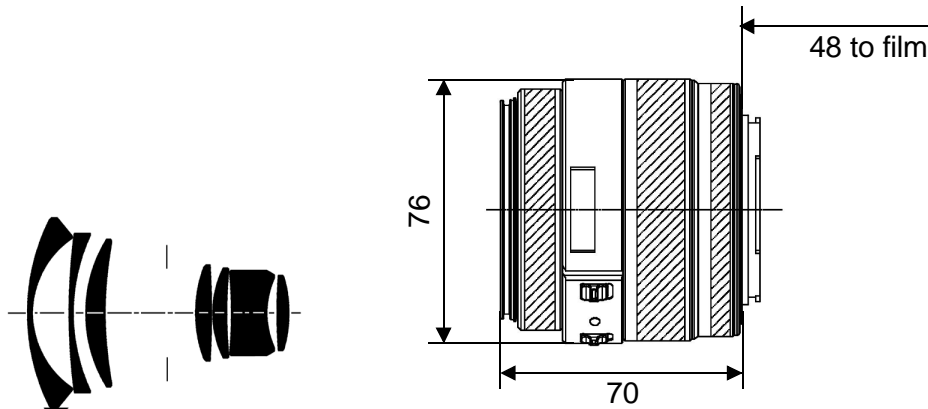

**CONTAX® N**

The Carl Zeiss Vario-Sonnar® T\* 3.5-5.6/28-80 lens is a very compact autofocus zoom lens in the Contax N system.

It offers the focal length range most often used in 35 mm photography, both indoors and outdoors. On top of this it has a built-in macro function, which enables close-ups with a magnification of up to 1:2. This allows to completely fill the frame with an object the size of a credit card. The lens weighs only 380 g. All this makes it a very convenient optic for the travelling photographer.

An aspheric lens element is used to achieve high imaging performance while keeping the lens compact. The Carl Zeiss T\* anti-reflex coating of the Vario-Sonnar® T\* 3.5-5.6/28-80 lens helps to prevent stray light and thus enables brilliant images with vibrant colors.

**Preferred use:** Travel, vacation, people, live-action

<b>Cat. No. of lens</b>	<b>10 47 69</b>	<b>Entrance pupil*</b>	
Number of elements	7	Position	W = 23.5 mm behind the first lens vertex T = 12.6 mm behind the first lens vertex
Number of groups	7	Diameter	W = 8.1 mm T = 13.1 mm
Max. aperture	f/3.5-5.6	<b>Exit pupil*</b>	
Focal length	W = 29.0 mm, T = 77.0 mm	Position	W = 24.2 mm in front of the last lens vertex T = 13.6 mm in front of the last lens vertex
Negative size	24 x 36 mm	Diameter	W = 19.8 mm T = 16.9 mm
Angular field 2w*	W = width 64°, height 45°, diagonal 73° T = width 11°, height 7.1°, diagonal 13°	<b>Position of principal planes*</b>	
Min. aperture	22	H	W = 40.6 mm behind the first lens vertex T = 29.6 mm behind the first lens vertex
Camera mount	Contax N	H'	W = 17.1 mm behind the last lens vertex T = 8.1 mm in front of the last lens vertex
Filter connection	M 55 x 0.75	<b>Back focal distance</b>	W = 46.1 mm T = 85.1 mm
Focussing range	infinity to 0.25 m	<b>Distance between first and last lens vertex*</b>	W = 80.4 mm T = 40.7 mm
Working distance (between mechanical front end of lens and subject)	W = 0.37 m, T = 0.11 m	<b>Weight</b>	380 g
Close limit field size	W = 353 mm x 544 mm T = 49 mm x 74 mm		
Max. scale	W = 1 : 14.3 T = 1 : 2.0		

\*at infinity



Performance data:

**Vario-Sonnar**® T\* 3.5-5.6/28-80

Cat. No. 10 47 69

### 1. MTF Diagrams

The image height  $u$  - calculated from the image center - is entered in mm on the horizontal axis of the graph. The modulation transfer  $T$  (MTF = Modulation Transfer Factor) is entered on the vertical axis. Parameters of the graph are the spatial frequencies  $R$  in cycles (line pairs) per mm given at the top of this page.

The lowest spatial frequency corresponds to the upper pair of curves, the highest spatial frequency to the lower pair. Above each graph, the f-number  $k$  is given for which the measurement was made. "White" light means that the measurement was made with a subject illumination having the approximate spectral distribution of daylight. Unless otherwise indicated, the performance data refer to large object distances, for which normal photographic lenses are primarily used.

### 2. Relative illuminance

In this diagram the horizontal axis gives the image height  $u$  in mm and the vertical axis the relative illuminance  $E$ , both for full aperture and a moderately stopped-down lens. The values for  $E$  are determined taking into account vignetting and natural light decrease.

### 3. Distortion

Here again the image height  $u$  is entered on the horizontal axis in mm. The vertical axis gives the distortion  $V$  in % of the relevant image height. A positive value for  $V$  means that the actual image point is further from the image center than with perfectly distortion-free imaging (pincushion distortion); a negative  $V$  indicates barrel distortion.

Modulation transfer  $T$  as a function of image height  $u$ .  
White light. Spatial frequencies  $R = 10, 20$  and  $40$  cycles/mm

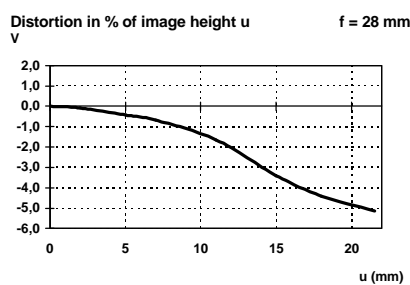
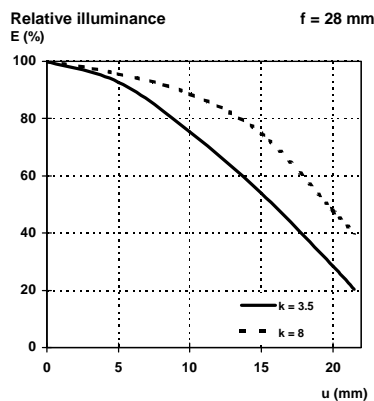
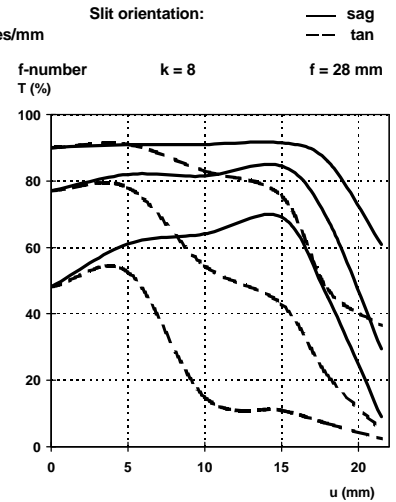
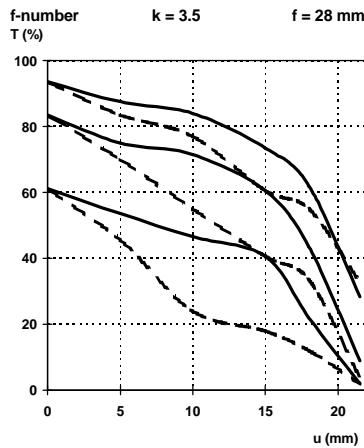

Performance data:  
**Vario-Sonnar® T\* 3.5-5.6/28-80**  
 Cat. No. 10 47 69

Modulation transfer T as a function of image height u.  
 White light. Spatial frequencies R = 10, 20 and 40 cycles/mm

Slit orientation:

— sag  
 - - - tan

f-number k = 4.5 f = 50 mm

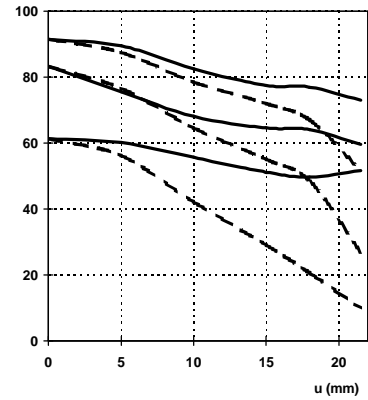

f-number k = 8 f = 50 mm

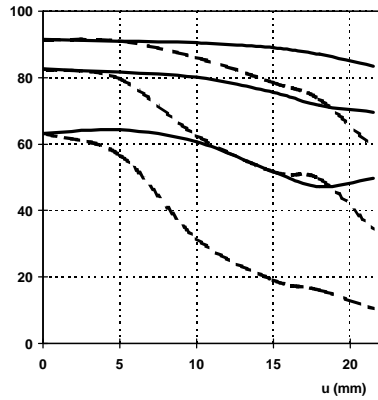

Relative illuminance E (%) f = 50 mm

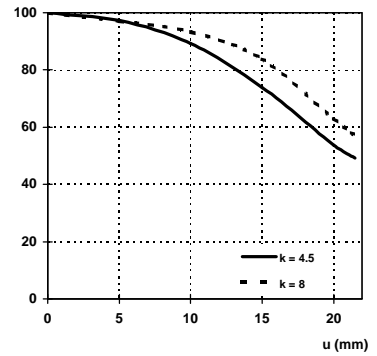

Distortion in % of image height u f = 50 mm

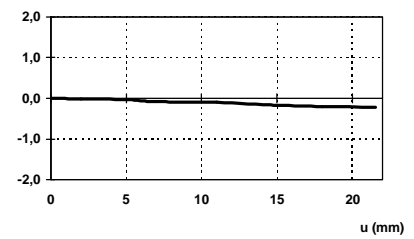

Performance data:  
**Vario-Sonnar® T\* 3.5-5.6/28-80**  
 Cat. No. 10 47 69

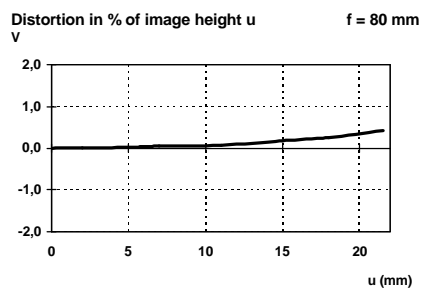
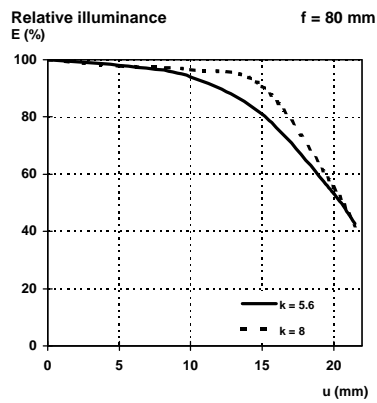
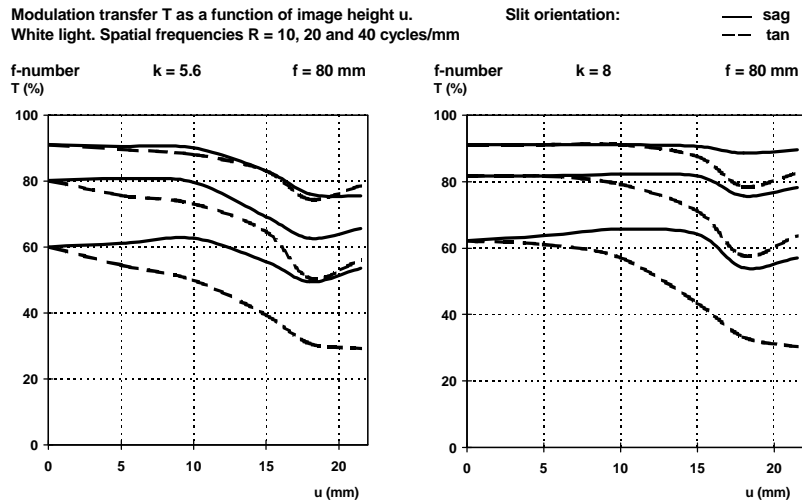

Subject to change.  
 Printed in Germany 29.05.2002



**Carl Zeiss**  
 Camera Lens Division  
 73446 Oberkochen  
 Germany  
 Telephone ++49-7364-20-6175  
 Fax ++49-7364-20-4045  
 eMail: photo@zeiss.de  
<http://www.zeiss.de/photo>